



RESEARCH ARTICLE

Thermoelastic response of a finite thick annular disc with radiation-type conditions *via* time fractional-order effects

Ravi Chaware^{1*}, Sajid Anwar², Sunil Prayagi³

Abstract

The study investigates thermal interactions in a two-dimensional time fractional-order thermoelastic problem in a homogeneous, isotropic, and perfectly conducting thick annular disc subjected to a point impulsive sectional heat source. We utilize unconventional integral transformation techniques to study the thermoelastic response of a disc, in which an internal heat source is generated according to the linear function of the temperature and radiation-type boundary conditions. The time fractional-order thermoelastic theory is used to determine temperature, displacement, and stresses through a series of Bessel functions. Numerical calculations analyze fractional-order parameters on aluminum discs, incorporating time-based fractional derivatives into field equations for practical engineering scenarios, enhancing thermal properties analysis.

Keywords: Transient response, Thick disc, Fractional-order derivative, Temperature distribution, Thermal stress, Integral transform.

Introduction

Fractional calculus gained popularity due to its ability to improve the accuracy of modeling dynamical systems, and recent applications such as mathematical approximation, chemical probing, fractal design, and thermoelastic modeling may confirm these theorems. The author provides a brief overview of the theoretical advancements in thermoelasticity theories. Povstenko (2009) conducted a thorough analysis of thermoelasticity using the fractional heat conduction equation. Sherief *et al.* (2010) developed a theory of thermoelasticity based on fractional order, which includes both coupled and generalized theories. Ezzat

(2011) and other researchers [Bhoyar *et al.* (2020), Bikram and Kedar (2021), Srinivas *et al.* (2021), Varghese *et al.* (2020)] further advanced this hypothesis, providing solutions to various challenges in thermoelasticity. Recently, Youssri *et al.* (2023) explored the time-fractional heat conduction equation in one dimension, including non-local temporal circumstances, and proposed a new numerical technique called the rectified Chebyshev Petrov-Galerkin procedure, which expands on the traditional Petrov-Galerkin approach. Nadeem *et al.* (2023) propose a method that uses the Aboodh transform and homotopy perturbation scheme to approximate solutions for time-fractional porous media and heat transport equations. Thus, fractional calculus has significantly altered many established theories of physical processes. It is also discovered that almost all literature neglects the radiation boundary conditions.

The manuscript combines previous research with Caputo fractional derivative's comprehensive uncoupled theory of thermoelasticity and recasts it into a practical application with radiation. Furthermore, the authors of this paper used simplified radiation models that provide reasonably accurate results without fully accounting for radiation boundary conditions. Thus, we have adopted alternative radiation boundary conditions in heat transfer analysis due to their inherent complexities in modeling radiation and the computational challenges they pose.

¹Department of Mathematics, Rashtrasant Tukadoji Maharaj Nagpur University, Nagpur, Maharashtra, India.

²Department of Mathematics, Anjuman College of Engineering and Technology, Nagpur, Maharashtra, India.

³Department of Mechanical Engineering, Yeshwantrao Chavan College of Engineering, Nagpur, Maharashtra, India.

***Corresponding Author:** Ravi Chaware, Department of Mathematics, Rashtrasant Tukadoji Maharaj Nagpur University, Nagpur, Maharashtra, India., E-Mail: ms.cbravi@rediffmail.com

How to cite this article: Chaware, R., Anwar, S., Prayagi, S. (2024). Thermoelastic response of a finite thick annular disc with radiation-type conditions *via* time fractional-order effects. The Scientific Temper, **15**(2):2078-2083.

Doi: 10.58414/SCIENTIFICTEMPER.2024.15.2.17

Source of support: Nil

Conflict of interest: None.

Notations

Θ	internal source function	Φ	thermodynamic temperature
----------	--------------------------	--------	---------------------------

κ	thermometric diffusivity	θ	temperature
ρ	density	e	dilatation
q	heat conduction vector	k	thermometric conductivity
∇T	temperature gradient	α	fractional-order
G	shear modulus	t	time
ν	Poisson's ratio	M	Michell's function
ϕ	Goodier's potential	U, W	displacements functions
C_v	calorific capacity	T_0	reference temperature
$\delta()$	Dirac Delta function	k_i	radiation coefficients
$E_{\alpha,\alpha}$	Mittag-Leffler function	s	Laplace parameter

Prerequisites of Fractional Calculus

The classical theory of heat conduction is based on the Fourier law $q(t) = -k \nabla T(t)$ in combination with the law of conservation by Biot (1956), which leads to the parabolic heat conduction equation $\partial T / \partial t = -\kappa \nabla^2 T$. Lord and Shulman (1967) introduced the idea of generalized thermoelasticity with a single relaxation period for an isotropic body. Caputo and Mainardi (1971) found that fractional derivatives accurately describe viscoelastic materials, connecting them to linear viscoelasticity theory. Green and Lindsay (1972) formulated the theory of generalized thermoelasticity with two relaxation durations based on a generalized thermodynamic inequality. Norwood (1972) and Moodi and Tait (1983) proposed a time-non-local equation $q(t) = -\kappa \int_0^t K(t-\tau) \nabla T(\tau) d\tau$. Chandrasekharaiah (1986) noted that the heat flux constitutive equation can be rewritten in a non-local form using the "short-tale" exponential time-non-local kernel $K(t-\tau) = \exp[-(t-\tau)/\zeta]$, $\zeta > 0$. Povstenko (2005a, 2005b) proposed the time-fractional heat conduction equation with a "long-tale" power kernel, which can be taken in terms of fractional integrals and derivatives based on the time-non-local dependence between flux vectors and gradients as $\partial^\alpha T / \partial t^\alpha = -\kappa \nabla^2 T$ and power kernel as

$$q(t) = \begin{cases} -k \frac{\partial}{\partial t} \int_0^t \frac{(t-\tau)^{\alpha-1}}{\Gamma(\alpha)} \nabla T(\tau) d\tau, & 0 < \alpha < 1, \\ -k \int_0^t \frac{(t-\tau)^{\alpha-2}}{\Gamma(\alpha)} \nabla T(\tau) d\tau, & 1 < \alpha < 2 \end{cases} \quad (1)$$

Here, we recall the definition by Caputo (1967) and Caputo and Mainardi (1969) of the fractional-order derivative $d^\alpha f(t) / dt^\alpha = I^{n-\alpha} D^n f(t)$ of the function $f(t)$ of order $n - \alpha$ is signified as

$$D_C^\alpha f(t) = I^{n-\alpha} D^n f(t) = \begin{cases} \int_0^t \frac{(t-\tau)^{n-\alpha-1}}{\Gamma(n-\alpha)} \frac{d^n f(\tau)}{d\tau^n} d\tau, & n-1 < \alpha < n, \\ \frac{d^n}{dt^n} f(t), & \alpha = n, \end{cases} \quad (2)$$

where $f(t)$ is a Lebesgue integrable function and Γ is the gamma function. Liang *et al.* (2015) suggested the Laplace transform rule that if $\alpha > 0$, $n = [\alpha] + 1$, and function $f(t)$ and its integer derivatives of order $k = 1, 2, \dots, n-1$ are continuous on $[0, +\infty)$ and of exponential order, while $D_C^\alpha f(t)$ is piecewise continuous on $[0, \infty)$. Then

$$\mathcal{L}[D_C^\alpha f(t)] = s^\alpha \mathcal{L}[f(t)] - \sum_{k=0}^{n-1} s^{\alpha-k-1} D^k f(0^+), \quad n-1 < \alpha < n \quad (3)$$

Statement of the Practical Problem

Fractional heat conduction in thick disc

The setup involves a thick annular disc with linear temperature function sources, isotropic and homogeneous material, and constant properties. The disc with a thickness of h is placed within space D , which is described by $a < r < b, -h < z < h$, as shown in Figure 1. The initial temperature, lower face, and curved surface of the disc are assumed to be at zero temperature, and its upper face is subjected to radiation-type boundary conditions with point impulsive sectional heat supply.

The heat conduction equation by Marchi and Fasulo (1967) and Kumar *et al.* (2013) with an internal heat source is taken as

$$\kappa \left[\frac{1}{r} \frac{\partial}{\partial r} \left(r \frac{\partial \theta}{\partial r} \right) + \frac{\partial^2 \theta}{\partial z^2} \right] + \Theta(r, z, t, \theta) = \frac{\partial^\alpha \theta}{\partial t^\alpha} \quad (4)$$

The undergiven functions are seen as the superposition of a simpler function by Paterson (1941)

$$\Theta(r, z, t, \theta) \equiv \Phi(r, z, t) + \psi(t) \theta(r, z, t) \quad (5)$$

and

$$T(r, z, t) = \theta(r, z, t) e^{-\int_0^t \psi(\zeta) d\zeta}, \quad \chi(r, z, t) = \Phi(r, z, t) e^{-\int_0^t \psi(\zeta) d\zeta} \quad (6)$$

and for the sake of brevity, we consider

$$\chi(r, z, t) = \frac{\delta(r-r_0) \delta(z-z_0) P(t)}{2\pi r}, \quad a \leq r_0 \leq b, -h \leq z_0 \leq h \quad (7)$$

Substituting Eqs. (5)-(7) into (1), one obtains

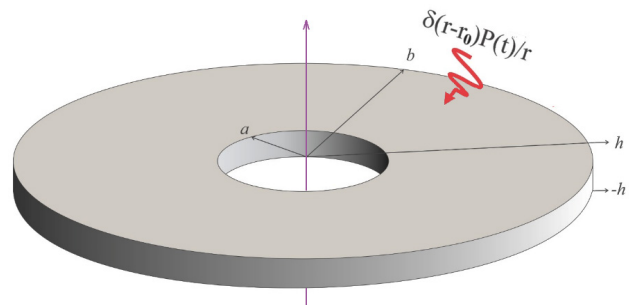

Figure 1: Thick annular disc configuration

$$\frac{\partial^\alpha T}{\partial t^\alpha} = \kappa \left[\frac{1}{r} \frac{\partial}{\partial r} \left(r \frac{\partial T}{\partial r} \right) + \frac{\partial^2 T}{\partial z^2} \right] + \chi(r, z, t) \tag{8}$$

subjected to the initial and boundary conditions

$$\left. \begin{aligned} T|_{r=0} &= 0, & 0 < \alpha < 1, \\ T|_{r=0} &= \frac{\partial T}{\partial t} \Big|_{t=0} = 0, & 1 < \alpha < 2, \end{aligned} \right\} \text{for all } a \leq r \leq b, -h \leq z \leq h \tag{9}$$

$$T + k_1 D_{RL}^{1-\alpha} \frac{\partial T}{\partial r} \Big|_{r=a} = 0, T + k_2 D_{RL}^{1-\alpha} \frac{\partial T}{\partial r} \Big|_{r=b} = 0, \text{ for all } -h \leq z \leq h, \tag{10}$$

$$t > 0$$

$$T + k_3 D_{RL}^{1-\alpha} \frac{\partial T}{\partial z} \Big|_{z=h} = f(r, t), T + k_4 D_{RL}^{1-\alpha} \frac{\partial T}{\partial z} \Big|_{z=-h} = 0 \text{ for all } a \leq r \leq b, \tag{11}$$

$$t > 0$$

where $f(r, t) = \delta(r - r_0)P(t)/r$ is the sectional heat supply.

Thermoelasticity in thick disc

The Navier's equations can be expressed as per Noda *et al.* (2003)

$$\frac{1}{r} \frac{\partial}{\partial r} \left(r \frac{\partial U}{\partial r} \right) + \frac{\partial^2 U}{\partial z^2} - \frac{U}{r} + \frac{1}{1-2\nu} \frac{\partial e}{\partial r} - \frac{2(1+\nu)}{1-2\nu} \alpha_i \frac{\partial \theta}{\partial r} = 0 \tag{12}$$

$$\frac{1}{r} \frac{\partial}{\partial r} \left(r \frac{\partial W}{\partial r} \right) + \frac{\partial^2 W}{\partial z^2} - \frac{1}{1-2\nu} \frac{\partial e}{\partial z} - \frac{2(1+\nu)}{1-2\nu} \alpha_i \frac{\partial \theta}{\partial z} = 0$$

and the dilatation as

$$e = \frac{\partial U}{\partial r} + \frac{U}{r} + \frac{\partial W}{\partial z} \tag{13}$$

with displacement function

$$U = \frac{\partial \varphi}{\partial r} - \frac{\partial^2 M}{\partial r \partial z}, \tag{14}$$

$$W = \frac{\partial \varphi}{\partial z} + 2(1-\nu) \left[\frac{1}{r} \frac{\partial}{\partial r} \left(r \frac{\partial M}{\partial r} \right) + \frac{\partial^2 M}{\partial z^2} \right] - \frac{\partial^2 M}{\partial z^2} \tag{15}$$

in which φ must satisfy

$$\frac{1}{r} \frac{\partial}{\partial r} \left(r \frac{\partial \varphi}{\partial r} \right) + \frac{\partial^2 \varphi}{\partial z^2} = \left(\frac{1+\nu}{1-\nu} \right) \alpha_i \theta \tag{16}$$

and the M must satisfy

$$\left[\frac{1}{r} \frac{\partial}{\partial r} \left(r \frac{\partial}{\partial r} \right) + \frac{\partial^2}{\partial z^2} \right] \left[\frac{1}{r} \frac{\partial}{\partial r} \left(r \frac{\partial}{\partial r} \right) + \frac{\partial^2}{\partial z^2} \right] M = 0 \tag{17}$$

The component of the stresses

$$\frac{\sigma_{rr}}{2G} = \frac{\partial^2 \varphi}{\partial r^2} - \left[\frac{1}{r} \frac{\partial}{\partial r} \left(r \frac{\partial}{\partial r} \right) + \frac{\partial^2}{\partial z^2} \right] \varphi + \frac{\partial}{\partial z} \left\{ \nu \left[\frac{1}{r} \frac{\partial}{\partial r} \left(r \frac{\partial}{\partial r} \right) + \frac{\partial^2}{\partial z^2} \right] M - \frac{\partial^2 M}{\partial r^2} \right\}, \tag{18}$$

$$\frac{\sigma_{\theta\theta}}{2G} = \frac{1}{r} \frac{\partial \varphi}{\partial r} - \left[\frac{1}{r} \frac{\partial}{\partial r} \left(r \frac{\partial}{\partial r} \right) + \frac{\partial^2}{\partial z^2} \right] \varphi + \frac{\partial}{\partial z} \left\{ \nu \left[\frac{1}{r} \frac{\partial}{\partial r} \left(r \frac{\partial}{\partial r} \right) + \frac{\partial^2}{\partial z^2} \right] M - \frac{1}{r} \frac{\partial M}{\partial r} \right\}, \tag{19}$$

$$\frac{\sigma_{zz}}{2G} = \frac{\partial^2 \varphi}{\partial z^2} - \left[\frac{1}{r} \frac{\partial}{\partial r} \left(r \frac{\partial}{\partial r} \right) + \frac{\partial^2}{\partial z^2} \right] \varphi + \frac{\partial}{\partial z} \left\{ (2-\nu) \left[\frac{1}{r} \frac{\partial}{\partial r} \left(r \frac{\partial}{\partial r} \right) + \frac{\partial^2}{\partial z^2} \right] M - \frac{\partial^2 M}{\partial z^2} \right\}, \tag{20}$$

$$\frac{\sigma_{rz}}{2G} = \frac{\partial^2 \varphi}{\partial r \partial z} + \frac{\partial}{\partial r} \left\{ (1-\nu) \left[\frac{1}{r} \frac{\partial}{\partial r} \left(r \frac{\partial}{\partial r} \right) + \frac{\partial^2}{\partial z^2} \right] M - \frac{\partial^2 M}{\partial z^2} \right\} \tag{21}$$

The mechanical boundary conditions are

$$\sigma_{rr} \Big|_{r=a} = \sigma_{rr} \Big|_{r=b} = 0 \tag{22}$$

The mathematical formulation is comprised of Eqs. (1) to (22).

Solution of the Problem

Transient heat conduction analysis

We present the unconventional integral transform by Marchi and Fasulo (1967) with its inversion theorem as

$$\bar{g}(n) = \int_a^b r g(r) S_p(k_1, k_2, \mu_n r) dr, \tag{23}$$

$$g(r) = \sum_{n=1}^{\infty} (\bar{g}_p(n) / C_n) S_p(k_1, k_2, \mu_n r)$$

and another integral transform by Marchi and Fasulo (1967) as

$$\bar{f}(m) = \int_{-h}^h f(z) P_m(z) dz, f(z, t) = \sum_{m=1}^{\infty} \frac{\bar{f}(m)}{\lambda_m} P_m(z) \tag{24}$$

Using Eqs. (23)-(24), and (3), and one obtains

$$\frac{d^\alpha \bar{T}(n, m, t)}{dt^\alpha} + \Psi^2 \bar{T}(n, m, t) = \Lambda_m r_0 S_0(k_1, k_2, \mu_n r_0) P(t) \tag{25}$$

where $\Lambda_m = \kappa P_m(h) / k_3 + P_m(z_0)$ and $\Psi^2 = \kappa(\mu_n^2 + a_m^2)$.

By applying the Laplace transform to Eq. (25) under initial conditions (9), one obtains

$$(s^\alpha + \Psi^2) \bar{T}^*(n, m, s) = \Lambda_m r_0 S_0(k_1, k_2, \mu_n r_0) P(s) \tag{26}$$

Using the inversion theorems in Eq. (26), one obtains

$$T(r, z, t) = \sum_{n=1}^{\infty} \sum_{m=1}^{\infty} \left\{ \Lambda_m r_0 S_0(k_1, k_2, \mu_n r_0) \left[\int_0^t \tau^{\alpha-1} E_{\alpha, \alpha}(-\Psi \tau^\alpha) P(t-\tau) d\tau \right] \right. \tag{27}$$

$$\left. \times P_m(z) S_0(k_1, k_2, \mu_n r) / \lambda_m C_n \right.$$

Hence, the solution of Eq. (4) is

$$\theta(r, z, t) = \left\langle \sum_{n=1}^{\infty} \sum_{m=1}^{\infty} \left\{ \Lambda_m r_0 S_0(k_1, k_2, \mu_n r_0) \left[\int_0^t \tau^{\alpha-1} E_{\alpha, \alpha}(-\Psi \tau^\alpha) P(t-\tau) d\tau \right] \right\} \right. \tag{28}$$

$$\left. \times \frac{P_m(z)}{\lambda_m C_n} S_0(k_1, k_2, \mu_n r) \right\rangle e^{\int_0^t \psi(\zeta) d\zeta}$$

Eq. (28) describes the temperature of a thick disk with finite height under radiation circumstances at any given time and position. Here, in Eq. (28), the eigenvalues μ_n are the positive roots of the characteristic equation $J_0(k_1, \mu a) Y_0(k_2, \mu b) - J_0(k_2, \mu b) Y_0(k_1, \mu a) = 0$. The kernel function $S_0(k_1, k_2, \mu_n r)$ can be defined as $S_0(k_1, k_2, \mu_n r) = J_0(\mu_n r) [Y_0(k_1, \mu_n a) + Y_0(k_2, \mu_n b)] - Y_0(\mu_n r) [J_0(k_1, \mu_n a) + J_0(k_2, \mu_n b)]$ with $J_0(k_i, \mu r) = J_0(\mu r) + k_i \mu J_0'(\mu r)$, $Y_0(k_i, \mu r) = Y_0(\mu r) + k_i \mu Y_0'(\mu r)$ for $i=1, 2$, and $C_n = \int_a^b r [S_0(k_1, k_2, \mu_n b)]^2 dr$, in which $J_0(\mu r)$ and $Y_0(\mu r)$ are Bessel functions of first and second kind of order $p=0$, respectively. Further, in Eq. (28), we define the kernel as given by the orthogonal functions as $P_m(z) = Q_m \cos(a_m z) - W_m \sin(a_m z)$ where $Q_m = a_m(k_3 + k_4) \cos(a_m h)$, $W_m = 2 \cos(a_m h) + (k_3 - k_4) a_m \sin(a_m h)$, $\lambda_m = \int_{-h}^h P_m^2(z) dz = h [Q_m^2 + W_m^2] + \sin(2a_m h) [Q_m^2 - W_m^2] / 2a_m$. The eigenvalues

a_m are the positive roots of the characteristic equation $[k_3 a \cos(ah) + \sin(ah)] [\cos(ah) + k_4 a \sin(ah)] = [k_4 a \cos(ah) - \sin(ah)] [\cos(ah) - k_3 a \sin(ah)]$.

Thermoelastic solution

We assume Goodier’s thermoelastic displacement potential as

$$\varphi = \left(\frac{1+\nu}{1-\nu} \right) \alpha_r \left\{ \sum_{n=1}^{\infty} \sum_{m=1}^{\infty} \left\{ \Lambda_m r_0^2 S_0(k_1, k_2, \mu_n r_0) \left[\int_0^t \tau^{\alpha-1} E_{\alpha, \alpha}(-\Psi \tau^\alpha) P(t-\tau) d\tau \right] \right\} \right. \quad (29)$$

$$\left. \times \frac{P_m(z)}{\lambda_m C_n \mu_n^2 \alpha_m^2} S_0(k_1, k_2, \mu_n r) \right\} e^{\int_0^t \psi(\zeta) d\zeta}$$

We assume Michell’s function satisfies the governed condition of equation (12) as

$$M = \left(\frac{1+\nu}{1-\nu} \right) \alpha_r \left\{ \sum_{n=1}^{\infty} \sum_{m=1}^{\infty} \left\{ \Lambda_m r_0^2 S_0(k_1, k_2, \mu_n r_0) \left[\int_0^t \tau^{\alpha-1} E_{\alpha, \alpha}(-\Psi \tau^\alpha) P(t-\tau) d\tau \right] \right\} \right. \quad (30)$$

$$\left. \times \frac{P_m(z)}{\lambda_m C_n \mu_n^2 \alpha_m^2} [A_n \sinh(\mu_n z) + B_n z \cosh(\mu_n z)] S_0(k_1, k_2, \mu_n r) \right\} e^{\int_0^t \psi(\zeta) d\zeta}$$

where A_n and B_n are constants that are determined using Eq. (22) as

$$A_n = \frac{A_0 [J_1(a\mu_n)A_1 + J_1(b\mu_n)A_2]}{B_5 B_6 - hW_m \sin(h\alpha) B_3 B_4}, \quad (31)$$

$$B_n = \frac{B_0 [J_1(b\mu_n)B_1 - J_1(a\mu_n)B_2]}{B_5 B_6 - hW_m \sin(h\alpha) B_3 B_4}$$

This approach involves the complete formulation of two displacement functions ϕ and M . Now, to determine the displacement and thermal stress components, the thermoelastic displacement potential ϕ and Michell’s function M is replaced with Eqs. (14)-(15) and (18)-(21). The specific equation is excluded here for the sake of brevity but is taken into account during the numerical computation.

Numerical Results, Discussion and Remarks

The numerical computations have been carried out for an aluminum disc with thermomechanical properties as taken by Kumar *et al.* (2013): Modulus of elasticity $E = 70 \text{ GPa}$, thermal diffusivity $\kappa = 84.18 \text{ m}^2/\text{s}$, Poisson’s ratio $\nu = 0.35$, Thermal expansion coefficient $\alpha = 23 \times 10^{-6} / ^\circ\text{C}$, Thermal conductivity $G, 204.2 \text{ W/mK}$. The study uses $k_r = 0.96$ constant radiation coefficients and measures physical parameters using inner radius ($a = 1 \text{ m}$), outer radius ($b = 4 \text{ m}$), thickness ($h = 2 \text{ m}$), and surrounding temperature as 150°C . The study examined the impact of thermal load on the plate through numerical calculations and MATHEMATICA software-generated figures. The analysis of Figures 2 through 7 reveals that the fractional parameter α significantly impacts all domains, and the results for the typical parabolic equation, where $\alpha = 1.0$, align with previous findings in thermoelasticity by Kumar *et al.* (2013). Figure 2 displays the temperature distribution when the thick annular disk is at $t = 0.75$, both in the radial and thickness directions. A notable temperature rise was seen in the radial direction of the disk, particularly at the onset of the inner radius. This phenomenon can perhaps be attributed to the buildup of

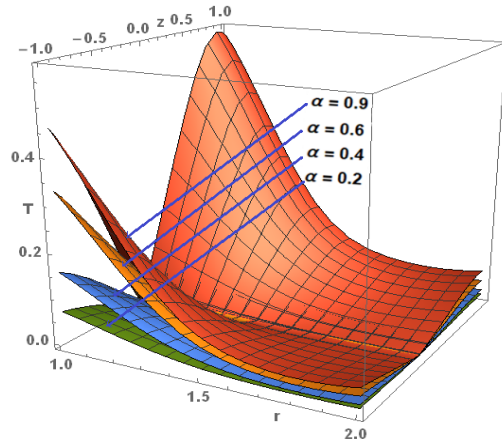

Figure 2: Temperature distribution along r- and z-direction for $t = 0.75$

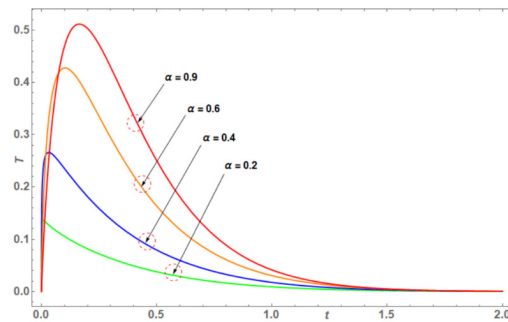

Figure 3: Temperature profile along t for various α values

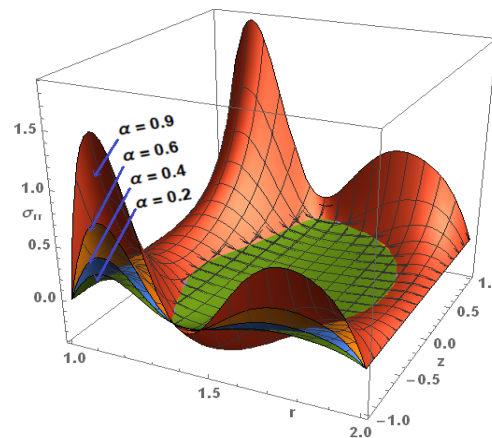

Figure 4: Radial stress distribution along r-axis and z-axis for $t = 1.25$

thermal energy resulting from the sectional heat supply. The propagation of disturbance within a medium leads to sudden changes, resulting in a non-uniform arrangement of temperature, diffusion, and strain field interactions.

The temperature decrease is expected to follow a gradual pattern in the radial direction. The temperature distributions throughout time t for cases $\alpha = 0.2, 0.4, 0.6,$ and 0.9 are depicted in Figure 3. At time $t = 0$, the temperature values are zero, then reach the maximum values due to accumulated heat, and subsequently, they steadily decrease

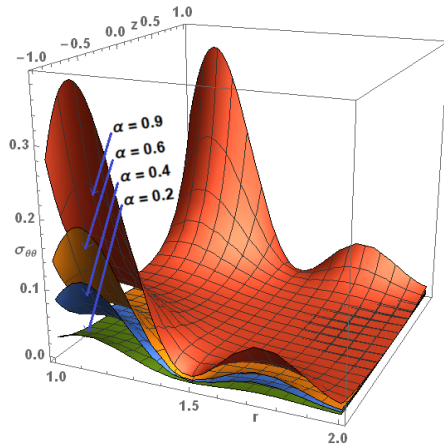

Figure 5: Tangential stress along r-axis and z-axis for $t = 0.25$

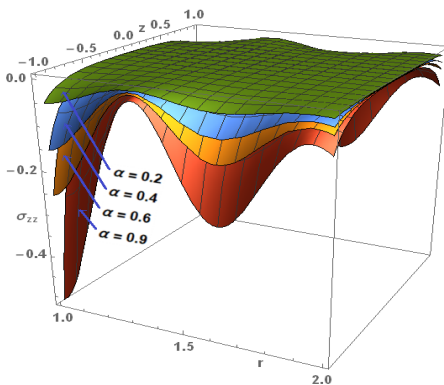

Figure 6: Axial stress for varying along r-axis and z-axis for $t = 0.75$

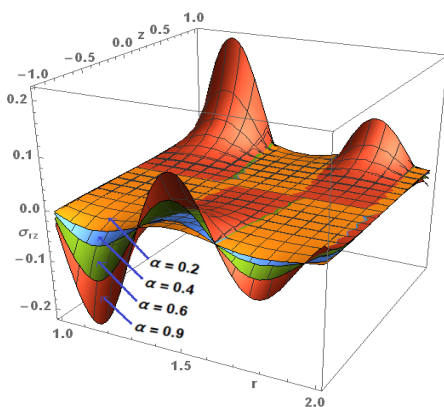

Figure 7: Shear stress for varying along r-axis and z-axis for $t = 0.25$

to zero. Figure 4 shows the radial stress distribution along the radial and thickness direction of the thick disc at $t = 0.75$. From the figure, the location of points of minimum stress occurs at the endpoints through the radial direction, while the thermal stress response is at zero, satisfying the traction-free conditions. The interior and outer edges tend to expand more than the inner portion, leading to the inner part being under tensile force. Figure 5 shows the tangential

stress distribution along the radial direction of the disc at $t = 0.75$. The tangential stress follows a sinusoidal nature with high crest and troughs at both ends, i.e., $r = 1$ and $r = 2$. In the thickness direction, it follows a U-shaped curve with a minimum value at the mid portion. Figure 6 shows the axial stress distribution, which is similar in nature but negative in magnitude as compared to the radial stress component along the r -axis and z -axis for $t = 0.75$. The axial stress values show greater negative fluctuations due to the higher compressive force on the inner curved surface compared to the outer curved surface. For small time $t = 0.07$ as well for large time $t = 0.75$. The axial stress values in the medium progressively rise towards the outside curve due to tensile force. The behavior and trend of variations in axial stress values for the CTE model show high similarity, except for their magnitudes. The central portion of the thickness experiences lower axial stress along the z -axis compared to the outer borders. Figure 7 shows the shear stress distribution along the radial and thickness direction of the thick disc at $t = 0.75$. Shear stress also follows more sine waveform with high peaks and troughs along the radial direction at $r = 1$ and $r = 2$, but minimum at the center part along the thickness direction.

Conclusion

This study focuses on the quasi-static uncoupled theory of fractional-order heat conduction, excluding the inertia element in the equation of motion. The study uses the temporal and spatial fractional differential operators to describe the impacts of memory and long-range interactions. The heat conduction equation is parabolic and designed to forecast wave propagation in terms of heat energy in an infinite manner. The study examines the fractional theory because it can predict a delayed reaction to physical stimuli, unlike the immediate response anticipated by the generalized theory of thermoelasticity. The research aims to explore the impact of fractional heat conduction on thermoelasticity using a quasi-static methodology. The authors Kumar and Kamdi (2020), in their Eq. (49), mistakenly neglected the Laplace convolution theorem during inverse transform calculation for temperature distribution, which was rectified and taken care of in our calculation.

Acknowledgment

The authors wish to thank the anonymous referees for their suggestions.

Author Contribution

All authors shared the same percentage.

References

Biot, M. A. (1956). Thermoelasticity and irreversible thermodynamics, *J. Appl. Phys.*, Vol. 27, no. 3, pp. 240-253. DOI: 10.1063/1.1722351
 Bikram, J., and Kedar, G. D. (2021). Study of thermoelastic behaviour, efficiency and effectiveness of rectangular fin with fractional

- order energy balance equation, *Int. J. Thermodyn.*, vol. 24, pp. 216–225, 2021. DOI: 10.5541/ijot.879603
- Caputo, M. (1967). Linear models of dissipation whose Q is almost frequency independent-II, *Geophys. J. Int.*, vol. 13, no. 5, pp. 529–539. DOI: 10.1111/j.1365-246X.1967.tb02303.x
- Caputo, M. (1969). *Elasticità e Dissipazione*, Zanichelli, Bologna.
- Caputo, M. and Mainardi, F. (1971). Linear models of dissipation in anelastic solids, *La Rivista del Nuovo Cimento*, Vol. 1, pp. 161–198. DOI: 10.1007/BF02820620
- Chandrasekharaiah, D. S. (1986). Thermoelasticity with second sound: A review, *Appl. Mech. Rev.*, vol. 39, no. 3, pp. 355–376. DOI: 10.1115/1.3143705
- Chandel, N., Khalsa, L., Prayagi, S., Varghese, V., Three-phase-lags thermoelastic infinite medium model with a spherical cavity via memory-dependent derivatives, *The Scientific Temper*, Vol. 15, No. 1, pp. 1726–1732, 2024. DOI: 10.58414/SCIENTIFICTEMPER.2024.15.1.21
- Ezzat, A. (2011). Magneto-Thermoelasticity with Thermoelastic Properties and Fractional Derivative Heat Transfer, *Physica*, vol. 406, pp. 30–35, 2011. DOI: 10.1016/j.physb.2010.10.005
- Green, A. E. and Lindsay, K. A. (1972). Thermoelasticity, *J. Elast.*, Vol. 2, pp. 1–7. DOI: 10.1007/BF00045689
- Kumar, R. Lamba, N. K. and Varghese V. (2013). Analysis of thermoelastic disc with radiation conditions on the curved surfaces, *Mater. Phys. Mech.*, Vol. 16, No. 2, pp. 175–186.
- Kumar, N. and Kamdi, D. B. (2020). Thermal behavior of a finite hollow cylinder in context of fractional thermoelasticity with convection boundary conditions, *J. Therm. Stresses*, Vol. 43, no. 9, pp. 1189–1204. DOI: 10.1080/01495739.2020.1776182
- Lord, H. W. and Shulman, Y. (1967). A generalized dynamical theory of thermoelasticity, *J. Mech. Phys. Solids*, Vol. 15, no. 5, pp. 299–309. DOI: 10.1016/0022-5096(67)90024-5
- Liang, S., Ranchao, W. and Chen, L. (2015). Laplace transform of fractional order differential equations, *Electr. J. Differ. Equ.*, Vol. 2015, no. 139, pp. 1–15.
- Marchi, E. and Fasulo, A. (1967). Heat conduction in sectors of hollow cylinder with radiation, *Atti. della Acc. delle Sci. di Torino*, Vol. 1, pp. 373–382. DOI: 10.1017/S0013091500025906
- Moodi, T. B. and Tait, R. J. (1983). On thermal transients with finite wave speeds, *Acta Mech.*, Vol. 50, pp. 97–104. DOI: 10.1007/BF01170443
- Norwood, F. R. (1972). Transient thermal waves in the general theory of heat conduction with finite wave speeds, *J. Appl. Mech.*, vol. 39, NO. 3, pp. 673–676. DOI: 10.1115/1.3422771
- Noda, N., Hetnarski, R. B. and Tanigawa, Y. (2003) *Thermal stresses*, Second ed. Taylor and Francis, New York.
- Nasser, M. E. (2005). A two-dimensional problem for a thick plate with heat sources in generalized thermoelasticity, *J. Therm. Stresses*, Vol. 28, no. 12, pp. 1227–1241. DOI: 10.1080/014957390967910
- Nadeem, M., Islam, A., Karim, S., Mureşan, S., and Iambor, L.F. (2023). Numerical analysis of time-fractional porous media and heat transfer equations using a semi-analytical approach, *Symmetry*, vol. 15, pp. 1374, 2023. <https://doi.org/10.3390/sym15071374>
- Paterson, S. (1941). The conduction of heat in a medium generating heat, *Lond. Edinb. Dubl. Phil. Mag.*, Vol. 32, no. 214, pp. 384–392. DOI: 10.1080/14786444108520798
- Povstenko, Y. Z. (2005). Fractional heat conduction equation and associated thermal stress, *J. Thermal Stresses*, Vol. 28, no. 1, pp. 83–102, 2005. DOI: 10.1080/014957390523741
- Povstenko, Y. Z. (2005). Stresses exerted by a source of diffusion in a case of a non-parabolic diffusion equation, *Int. J. Engng Sci.*, vol. 43, pp. 977–991. DOI: 10.1016/j.ijengsci.2005.03.004
- Povstenko, Y. Z. (2009). Thermoelasticity that uses fractional heat conduction equation, *J. Math. Sci.*, vol. 162, pp. 296–305, 2009. DOI: 10.1007/s10958-009-9636-3
- Sherief, H., El-Sayed, M., and Abd El-Latif, M. (2010). Fractional order theory of thermoelasticity, *Int. J. Solids Structures*, vol. 47, pp. 269–275, 2010. DOI: 10.1016/j.ijsolstr.2009.09.034
- Bhoyar, S., Varghese, V., and Khalsa, L. (2020). An exact analytical solution for fractional-order thermoelasticity in a multi-stacked elliptical plate, *J. Therm. Stresses*, vol. 43, no. 6, pp. 762–783. DOI: 10.1080/01495739.2020.1748553
- Srinivas, V. B., Manthana, V. R., Bikram, J., and Kedar, G. D. (2021). Fractional order heat conduction and thermoelastic response of a thermally sensitive rectangular parallelepiped, *Int. J. Thermodyn.*, vol. 24, pp. 62–73, 2021. DOI: 10.5541/ijot.849663
- Varghese, V., Bhoyar, S., and Khalsa, L. (2021). Thermoelastic response of a nonhomogeneous elliptical plate in the framework of fractional order theory, *Arch Appl Mech*, vol. 91, pp. 3223–3246, 2021. DOI: 10.1007/s00419-021-01962-w
- Yousri, Y. H., Ismail, M. I., and Atta, A. G. (2023). Chebyshev Petrov-Galerkin procedure for the time-fractional heat equation with non-local conditions, *Physica Scripta*, vol. 99, no. 1, pp. 015251, 2023. DOI: 10.1088/1402-4896/ad1700

Appendix

$$A_0 = [Y_0(k_1, \mu_n a) + Y_0(k_2, \mu_n b)] \tan(ha_m)$$

$$A_1 = hW_m \sin(ha_m) [-Q_m [Y_0(k_1, \mu_n a) + Y_0(k_2, \mu_n b)] + [2\mu_n(\nu - 1) + a_m \nu] S'_0(k_1, k_2, \mu_n b) \sin(ha_m)]$$

$$A_2 = S'_0(k_1, k_2, \mu_n a) [-2\mu_n(\nu - 1) + hW_m a_m \nu \sinh(ha_m)] + Q_m [Y_0(k_1, \mu_n a) + Y_0(k_2, \mu_n b)] \sinh(ha_m) Y_1(\mu_n a)$$

$$B_0 = [Y_0(k_1, \mu_n a) + Y_0(k_2, \mu_n b)] Q_m \sin(ha)$$

$$B_1 = [2\mu_n(\nu - 1) + a_m \nu] S'_0(k_1, k_2, \mu_n a) \sin(h\mu_n) - Q_m [J_0(k_1, \mu_n a) + J_0(k_2, \mu_n b)] Y_1(a\mu_n) \sin(ha_m)$$

$$B_2 = [2\mu_n(\nu - 1) S_0(k_1, k_2, \mu_n b) + a_m \nu S'_0(k_1, k_2, \mu_n b)] \sinh(ha_m) - Q_m [J_0(k_1, \mu_n a) + J_0(k_2, \mu_n b)] Y_1(b\mu_n) \sin(ha_m)$$

$$B_3 = Q_m [Y_0(k_1, \mu_n a) + Y_0(k_2, \mu_n b)] \sinh(ha_m) - [2\mu_n(\nu - 1) + a_m \nu] S'_0(k_1, k_2, \mu_n b) \sin(h\mu_n)$$

$$B_4 = [2\mu_n(\nu - 1) + a_m \nu] S'_0(k_1, k_2, \mu_n a) \sin(ha_m) - Q_m [Y_0(k_1, \mu_n a) + Y_0(k_2, \mu_n b)] \sinh(ha_m) Y_1(a\mu_n)$$

$$B_5 = S'_0(k_1, k_2, \mu_n a) [2\mu_n(\nu - 1) + hW_m a_m \nu \sinh(ha_m)] - Q_m [Y_0(k_1, \mu_n a) + Y_0(k_2, \mu_n b)] \sinh(ha_m) Y_1(a\mu_n)$$

$$B_6 = [2\mu_n(\nu + 1) S_0(k_1, k_2, \mu_n b) + a_m \nu S'_0(k_1, k_2, \mu_n b)] \sinh(ha_m) - Q_m [Y_0(k_1, \mu_n a) + Y_0(k_2, \mu_n b)] \sinh(ha_m) Y_1(b\mu_n)$$